

Tour Guide System PASS 650TG - Manual

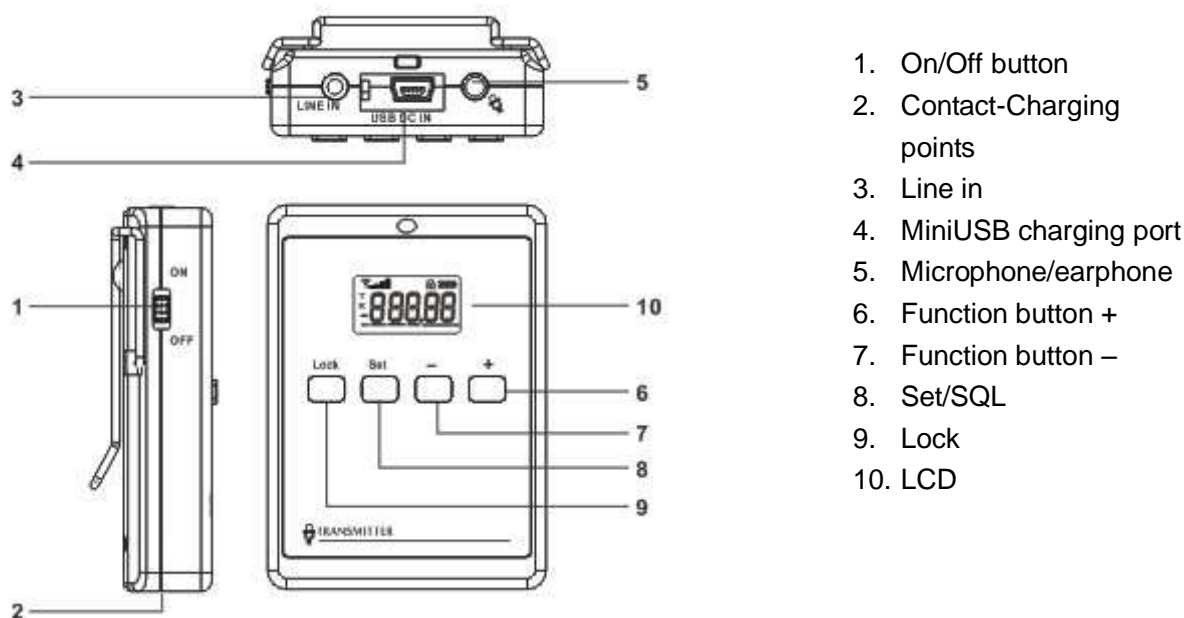

1. On/Off button
2. Contact-Charging points
3. Line in
4. MiniUSB charging port
5. Microphone/earphone
6. Function button +
7. Function button -
8. Set/SQL
9. Lock
10. LCD

Operation:

1. Switch On/Off: Switch up is on, switch down is off. When switching on, the device is locked.
2. Unlock/Lock: Keep pushing Lock for 3 seconds to unlock/lock. Device is locked when display showing a Lock. Note: If no operation in 10 seconds after unlocking, the device will turn to locked mode automatically.
3. Change Channel: When device is unlocked, push - or + to change channels, the display will show channel number (1-99). When the transmitter and receiver are in the same channel, they will be working.
4. Transmitter VOL: When unlocked, push SET to change transmitter volume. Choose 1-2 for microphone input, 2 will transmit a larger sound; **choose 1 for audio line input such as mp3 player.**
5. Transmitter Mute: When transmitter is locked, you can press SET for 3 seconds to mute your microphone. The vol on the LCD will flash when it mutes. Press SET again to switch back.
6. Receiver volume Control: When receiver is on and locked, use < and > to adjust volume. At the same time, the display will show (1-15) volume number.
7. Receiver SQL (Squelch) on/off Adjustment: To reduce noise at different location, you can adjust receiver squelch (0-9) off level. When the signal to receiver is too weak and noise is large, receiver will automatically stop receiving signal according to this setting. **When receiver is on and unlocked, push set to adjust. 0 means receiver keep receiving signal at any location and the distance is maximal, 9 means even slight noise will shut off the receiver. Usually 1 is a good level.**

- Receiver automatic turn off: Receivers delivered after 2014 March will have the function of automatic turning off after 20 min without receiving signal from transmitter. If the receiver turns off, you need to switch off then switch on the on/off button to turn on the receiver.
- Charging: Please use DC5V/800mA charger. When charging, the red light on the back of the display is on. When charging is finished, the red light will be off. We supply “drop in” charging station for large amount of device to be charged at the same time. The charging time is about 4 hours.

Hints for application:

If two groups are located in a very short distance, nearby channels might generate an interference. In this case, in stead of using two close channels, for example, CH1 and CH2, please use channels with more difference, for example, CH1 and CH5, to eliminate the interference between groups.

If the receiver volume is over 10, you can hear a slight noise. In this case, please adjust the transmitter volume to maximal level, then you can reduce the receiver volume to avoid the noise.

How to setup two guides for one group:

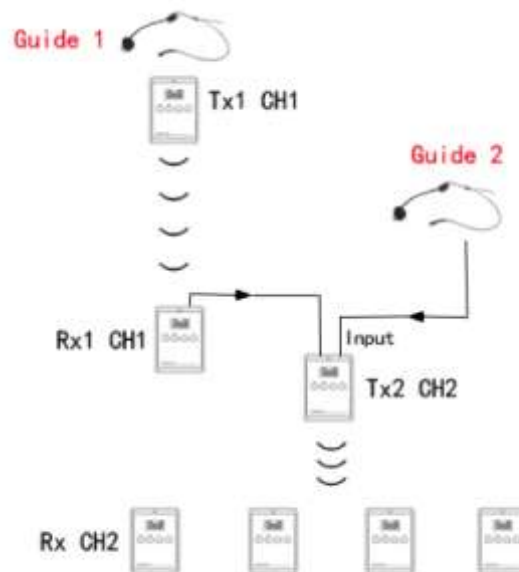

Specifications:

Parameter	Value
Wave band	794-806 MHz,863-865MHz, 902-915MHz
Output Power	13 dBm
Frequency Response	20-16kHz
Sensitivity	-115 dBm
deviation	+/-100k
Modulation	FM, PLL
Distance	200 m (Open ground/without interference)
S/N ratio	>60 db
Input	microphone/audio
Output	earphone/audio
No. of Channels	50-100 (adjustable)
Power supply	Rechargeable Lithium Battery
Dimension	72mm x 52mm x 16mm